

LETTERBOX FASCIA

# Installation Guide



**IMPORTANT**

Pier/Wall surfaces to be finished prior to installing letterbox fascia and rear door panel.

What you'll need:

- Pencil
- Spirit Level
- Drill, with 8-12mm bit
- 'Liquid Nails' or Equivalent
- Props

## How to Install Letterbox Fascia

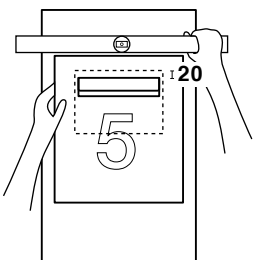
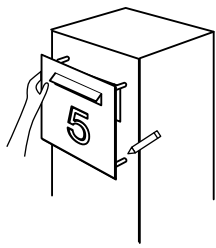
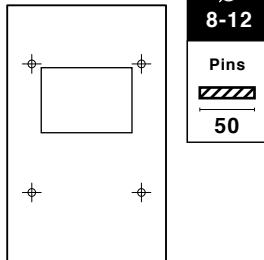
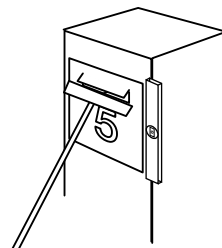
<p><b>1</b></p>  <p>Hold the fascia in position over letterbox aperture, the letter slot should be approximately 20 mm below the top edge of the aperture.</p>	<p><b>2</b></p>  <p>Mark the location of the four pins.</p>	<p><b>3</b></p>  <p>Drill 8 to 12 mm diameter holes to a depth of at least 50mm, make sure holes are dry and free of dust, fill with "Liquid Nails" or similar.</p>	<p><b>4</b></p>  <p>Push pins into holes and plate hardup to wall, check final alignment and prop panel, allow to set for 24 hrs.</p> <p style="text-align: right;"><b>24HR SET</b></p>
--	---	--	---

## How to Install Rear Door Panel

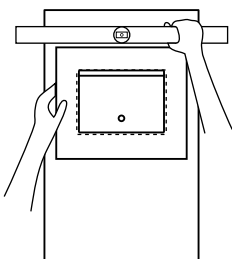
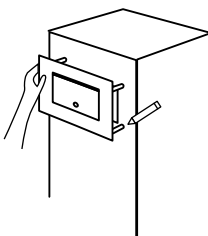
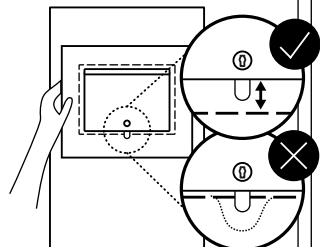
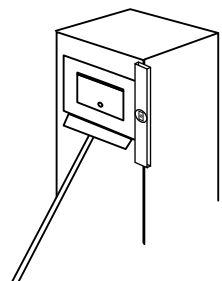
<p><b>1</b></p>  <p>Remove keys from back of door and align panel over letterbox aperture.</p>	<p><b>2</b></p>  <p>Mark the location of the four pins, drill 8 to 12 mm diameter holes to a depth of at least 50mm.</p> <p style="text-align: right;"><b>Holes</b> ∅ 8-12 <b>Pins</b> 50</p>	<p><b>3</b></p>  <p>Before gluing hold plate in position and check the lock tongue clears bottom edge of aperture. It may be necessary to chip masonry away.</p> <p style="text-align: right;"><b>24HR SET</b></p>	<p><b>4</b></p>  <p>Make sure holes are dry and free of dust, fill with "Liquid Nails" or similar, push pins into holes and plate hardup to wall, check final alignment and prop panel, allow to set for 24 hrs.</p> <p style="text-align: right;"><b>24HR SET</b></p>
---	--	--	---